

ФЕДЕРАЛЬНОЕ АГЕНТСТВО ПО ОБРАЗОВАНИЮ  
ГОСУДАРСТВЕННОЕ ОБРАЗОВАТЕЛЬНОЕ УЧРЕЖДЕНИЕ  
ВЫСШЕГО ПРОФЕССИОНАЛЬНОГО ОБРАЗОВАНИЯ  
«САМАРСКИЙ ГОСУДАРСТВЕННЫЙ АЭРОКОСМИЧЕСКИЙ  
УНИВЕРСИТЕТ имени академика С.П. КОРОЛЕВА»

ОБУЧЕНИЕ УСТНОЙ И ПИСЬМЕННОЙ РЕЧИ  
ПО ТЕМЕ «ЭКСПЛУАТАЦИЯ  
ЛЕТАТЕЛЬНЫХ АППАРАТОВ»  
(АНГЛИЙСКИЙ ЯЗЫК)

*Утверждено Редакционно-издательским советом университета  
в качестве методических указаний по английскому языку*

САМАРА  
Издательство СГАУ  
2010

УДК 43  
ББК СГАУ: Ш143.21

Составители: *А.Г. Лещенко, С.А. Егоров*

Рецензент О.Н. М а р и н и н а

**Обучение устной и письменной речи по теме «Эксплуатация летательных аппаратов»:** метод. указания по англ. языку/ сост. *А.Г. Лещенко, С.А. Егоров*. – Самара: Изд-во Самар. гос. аэрокосм. ун-та, 2010. - 44 с.: ил.

Предназначены для студентов 2 курса 3 факультета и направлены на развитие умений и навыков поискового и изучающего чтения с элементами аннотирования и реферирования и устной речи по авиационной тематике.

Данный материал включает в себя лексические упражнения, тексты для взаимосвязанного обучения устной речи и чтению, а также закреплению активной лексики и повторению основных грамматических явлений.

УДК 43  
ББК СГАУ: Ш143.21

---

*Учебное издание*

**ОБУЧЕНИЕ УСТНОЙ И ПИСЬМЕННОЙ РЕЧИ  
ПО ТЕМЕ «ЭКСПЛУАТАЦИЯ ЛЕТАТЕЛЬНЫХ АППАРАТОВ»**

*Методические указания по английскому языку*

Составители: *Лещенко Артур Геннадьевич  
Егоров Сергей Александрович*

Подписано в печать 12.04.2010 г. Формат 60x84 1/16  
Бумага офсетная. Печать офсетная. Печ. л. 2,75  
Тираж 100 экз. Заказ .

Самарский государственный аэрокосмический университет.  
443086 Самара, Московское шоссе, 34.

Изд-во Самарского государственного аэрокосмического университета.  
443086 Самара, Московское шоссе, 34.

---

© Самарский государственный  
аэрокосмический университет, 2010



## Unit 1

### TOPIC: BASIC CONSTRUCTION FEATURES OF THE MAIN PLANES

#### I. Pre- Reading

1. *Before you read the text answer the following questions.*

- 1) What is a wing? Give the definition in your own words.
- 2) What types of wings do you know?
- 3) What parts does the wing consist of?
- 4) What is the main function of the skin?

2. *Put the right words with the different parts of the plane.*

Spinner; Propeller; Engine Cowl; 1.-

8.- 15.-

Windshield Wing; Strut Wing; 2.-

9.-	16.-
Right Aileron; Right Flap; Fuselage;	3.-
10.-	17.-
Vertical Stabilizer; Rudder; Elevator;	4.-
11.-	18.-
Horizontal Stabilizer; Left Flap;	5.-
12.-	19.-
Left Aileron; Main Landing Gear; Door;	6.-
13.-	20.-
Seat; Nose Gear; Landing Lights.	7.-
14.-	

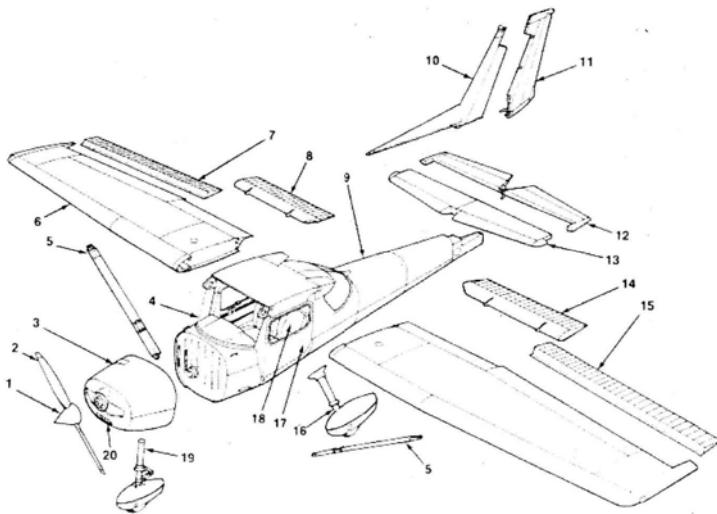

## II. Reading

1. Now read the text and highlight the ideas not mentioned in the discussion.

*Wing Structure.* There are many types of wings used at present time. There is all-wood, fabric-covered construction. There is the composite type with wood spars and metal ribs. This type is covered with fabric and differs little from the previous type. The next type is that with metal spars and metal ribs covered with fabric. The fourth type is made entirely of metal including cover.

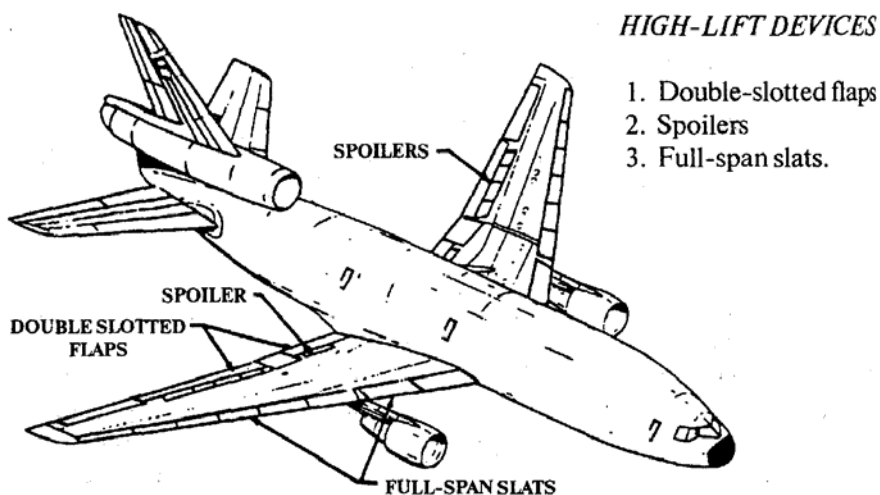

One of the numerous arrangements of the wing assembly is shown on Fig. 6. Two main spars are used, with ribs and bulkheads placed at frequent intervals to space the spars and to develop the wing contour. The ribs shown are stamped from one piece; however, they may be built-up sections or trusses. Other wings utilize a single spar, while still others use three or more. In some lighter airplanes, spars and ribs are made of wood. Frequently the larger compartments of wings contain, or are themselves used as, gasoline tanks or flotation cells. Wings of large airplanes are usually aluminum alloy covered. Cantilever wings are generally of the stressed-skin type.

The skin is a part of the basic wing structure, carrying part of the wing stresses. Some metal-framed and wood-framed wings are fabric-covered with the exception of the leading edge, where aluminum alloy or plywood is employed. This presents a smooth, uniform surface to the air stream and supplies the strength necessary to withstand the air pressure.

The wings of an aeroplane are not made in one single piece from one wing tip to the other. The usual method of construction is to build the wings in three main sections, namely, the center section which extends across the fuselage and projects outwards at each side, the port main plane and the starboard main plane. The center section may be built as an integral part of the fuselage or it may be a separate unit, but in the latter case the design will be such that when it is assembled to the fuselage, the two parts will fit snugly together as though they had been built as one unit. The outer main planes will be further subdivided into their respective components such as main planes proper, ailerons, flaps and wing tips. On most airplane wings, the tips are small units bolted to the outer end of the outboard panel. This construction provides an easy method of correcting damage which wood otherwise frequently requires the replacement of large wing panels. Wherever wing sections are bolted to each other or to the fuselage stubs, metal terminal fittings are used to furnish the required strength. It is sometimes necessary to walk on reinforced parts in order to enter the cockpit. In such cases, walkways are prepared to cover the parts of wings where such protection is needed.

*Ailerons.* The method of construction used in the main planes proper is usually continued in ailerons.

The principal member in normal aileron design is the spar. Since this is not subjected to bending and shear loads, but also to torsion, a tube is particularly suitable. The torsion applied to it by operating level is resisted by the air load on the surface, which is carried back through the ribs. The ribs are pressed from aluminium alloy and attached to the spar by means of long bolts, which pass through the flanged location plates. The trailing edge is the conventional oval or streamline section tube fastened to the ribs by wrapper plates, and the diagonal member braces the aileron laterally.

*Wing Flaps.* Relatively large airfoils hinged to the trailing edge of the wings near the fuselage are called “wing flaps”. Three general types are described below.

1. The plain type when in neutral appears almost to be a part of the wing itself, but it is hinged so that it can be moved downward as desired.

2. In the split trailing edge type, the lower half of the trailing edge of the wing is hinged so that the flap can be lowered. The upper half may also be hinged, so that it can be raised to increase drag without increasing the lift.

3. The Fowler flap is an arrangement by which the lower part of the trailing edge of the wing rolls back on a track. This movement increases the effective width of the wing and lowers the trailing edge about 40° below its retracted position.

*Operation.* Most flaps are operated by the main hydraulic system, which is used also to retract the landing gear and to perform other functions. A few flaps are electrically or manually operated. Auxiliary controls, manually operated, are usually added for use in emergencies. Linkages between the controls and flaps are of the same types and require the same inspections and service as these used on other movable surfaces. Flaps increase the drag and the lift of airplane wings. Increased drag permits the airplane to dive or glide at a steep angle without the excessive increase in speed which would otherwise occur. Thus, airplanes equipped with flaps may land more easily on a field there they must make an approach over obstructions. Increased lift also permits the airplane to land at lower speed than is normally possible.

*Slots.* Some airplanes have an air passage between the leading edge of the wing and a slat attached to the wing by brackets; some have a passage built permanently into the leading edge of the wing; and some have a passage which is opened automatically as a section of the leading edge rolls forward on a track when the airplane tilts upward at a steep angle. These passages are called slots. The air stream that flows through this slot when the airplane has a high angle of attack helps to maintain proper flow of air above the wings. This in turn makes it possible for an airplane with slots to fly at a steeper angle of attack without stalling than would otherwise be

possible. Slots also permit an airplane moving slowly as it approaches a landing on a small field to reduce speed still more without going into a complete stall when the nose is slightly tilted up.

### III. Post- Reading

1. Read the text again and make a list of all unfamiliar words. Compare them with your partner. In pairs try to guess the meaning of these words.

2. In the text, find the definitions of 'rib', 'spar', 'ailerons', 'wing flaps', 'leading edge', 'trailing edge', 'lift'.

3. Find the English equivalents for the following Russian words:

- |   |                     |
|---|---------------------|
| 1. крыло                                  | 1. type             |
| 2. особенность, свойство, признак, деталь | 2. wing             |
| 3. тип                                    | 3. feature          |
| 4. различаться, отличаться                | 4. spar             |
| 5. лонжерон (крыла)                       | 5. to include       |
| 6. закрывать, покрывать                   | 6. to cover         |
| 7. заключать, включать, содержать в себе  | 7. to differ (from) |



## IV. Vocabulary Work

*1. Read and translate the words. Use the dictionary if it is necessary.*

*Try to memorize them:*

to glide; to occur; to roll to; subject to; arrangement; bulkhead; fuselage stub; linkhead; sheer; slat; stall.

*2. Read and translate the following word combinations into Russian.*

*Try to use them in the sentences of your own:*

the method of construction, basic construction features, main types of wings, one of the numerous arrangements, the basic wing structure, in one single piece, to enter the cockpit.

*3. Complete the sentences so that they make sense:*

1. There is the all-wood, fabric-covered . . . .
2. There is the composite type with wood spars and . . . . .
3. The fourth type is made entirely . . . . .
4. There are many types of wings used . . . . .

*4. Translate the following English sentences into Russian:*

- The function of stabilizer is to stabilize the aircraft in flight.
- The function of immovable tail surfaces is to provide the steady motion of the aircraft.
  - The function of the landing gear is also to provide taxiing, take-off and landing.
  - The function of the landing gear is to support the aircraft on the ground.
  - The functions of the wings are to provide lift and low landing speed.
  - The functions of the flight control surfaces are to control and stabilize the aircraft in flight.

## V. Speaking

*1. In groups, think about basic construction features of the main planes.*



## Unit 2

### TOPIC: INSPECTION AND MAINTENANCE OF AEROPLANE UNITS

#### I. Pre- Reading

*1. Before you read the text answer the following questions.*

1. What is essential in inspecting the wing?
2. Where does corrosion often occur?
3. Why should the operator keep drain holes open?
4. Which items require special attention in inspection and maintenance of movable surfaces?



## II. Reading

1. Read the text and check whether your answers were correct.

*Skin and Protective Coating.* In the inspection of wings, fuselages, and similar structures, it is very important to watch for evidence of corroded or cracked skin, and injuries to protective coating.

1. Since corrosion is most likely to occur in pockets and corners on the inside where or salt spray may accumulate, drain holes must always be kept on. Internal members may also be broken or distorted and weakened as the result of unusually violent manoeuvres, extremely rough air or hard landings. Buckled or displaced covering, loosened rivets, etc., may indicate internal failure. Parallel wrinkles may indicate warped frame members. In case such external conditions develop, the condition of the internal structure must be thoroughly investigated and repairs made if necessary.

2. Small cracks leading away from rivets frequently occur in the metal covering. They are usually caused by vibration. As a temporary means of arresting the development of such cracks, small holes are drilled at the extremities or just beyond. Permanent repair is made by patching. Since the aluminum-alloy sheet used for covering is very springy and hard to bend, it is likely to crack if one tries to straighten sections that are bent or dented.

3. Aluminum-alloy surfaces from which the protective coating has been chipped, scratched, or worn, thus exposing the metal, should be recoated at once, since corrosion develops very rapidly.

*Engine Mounts.* Cracked, bent, or broken members of engine mounts are extremely dangerous and, without exception, must be repaired or replaced by the personnel authorized to do such work, before the airplane is again permitted to be flown. Cracks are most likely to occur at welded joints and, if small, may be difficult to discern through the protective coating. This is especially true if the structure is not kept thoroughly clean. Special care must be exercised in inspecting for such cracks. If not properly tightened, mounting clamps and bolts will allow movement of the mount, with consequent rapid wear of the bolts, elongation of bolt holes, and

serious vibration. When damaged, protective coatings should be retouched promptly to prevent the rusting of exposed steel surfaces.

*Cowling and Fairing.* Care must be exercised in the handling of cowling or fairing so that it will not be bent or broken. Many pieces, especially long strips or large sections, are not sufficiently rigid to support their weight unaided. Smaller parts, although formed so they are rigid as a unit, may be constructed of light gage material which is easily damaged. Cracks and dents will be repaired as on other sheet metal parts. All attachment devices must be kept in working condition and replaced at first sign of looseness or excessive wear. The finish of cowling or fairing must be kept intact, and if marred during assembly, should be retouched as soon as practicable. Where motion is necessary between pieces of installed cowling, chafing strips of fabric or fiber are used. These should be renewed whenever wear might permit metal parts to rub together.

The various items which require special attention in inspection and maintenance of movable surfaces are –

*Security.* The security of attachment of movable surfaces must be checked periodically. Such parts loosen more readily than those which are stationary. Bolts, hinges, as well as those on the rollers and tracks must be secured and safe tied. All such units also have full, free movement to perform the service required.

*Condition of Surfaces.* The frames of these surfaces must be kept free from corrosion, breaks, and warping. Metal surfaces must be checked for cracks, loose rivets etc.



### III. Post- Reading

1. Read the text again and make a list of all unfamiliar words. Compare them with your partner. In pairs try to guess the meaning of these words.

2. Find the Russian equivalents for the following English words:

to arrest	чрезвычайный
permanent	указывать
to prevent	особенно
stationary	постоянный
structure	предотвратить
to indicate	задержать
extreme	осмотр
to form	конструкция, устройство
especially	стационарный
inspection	образовывать, придавать форму

3. Answer the questions on the content of the text:

- 1) What may cause failure of internal structure?
- 2) What are cracks in the metal covering caused by?
- 3) What are the requirements of cowling and fairing handling?
- 4) Why should mounting clamps and bolts be well tightened?

## IV. Vocabulary Work

*1. According to the forms define to what parts of speech these words belong and translate them:*

1. to corrode – corroded – corrosion;
2. evidence – evident – evidently;
3. to indicate – indicator – indication;
4. to cover – covering;
5. extreme – extremely – extremity;
6. straight – to straighten;
7. weak – to weaken;
8. tight – to tighten;
9. loose – to loosen;
10. to protect – protective – protection;
11. to move – movement – movable;
12. to fail – failure;
13. danger – dangerous;
14. excess – excessive – excessively;
15. to join – joint – jointly.

2. *Read and translate the words. Use the dictionary if it is necessary. Try to memorize them:*

to arrest; chafing strip; cowling; clamp; to distort; drain hole; to dent; evidence; fairing; failure; injury; security; spray; to warp; welded joints; wrinkle;

3. *Translate the combinations of modal verbs and passive voice constructions into Russian:*

1. should be renewed;
2. may be constructed;
3. must be kept in working condition;
4. care must be exercised;
5. may be indicated;
6. should be arrested;
7. can be broken

4. *In the text find the English equivalents to the following word-combinations:*

1. дренажное отверстие следует держать открытым,
2. указывать на внутреннюю неисправность,
3. важно следить за признаками коррозии,
4. способ задержать распространение трещин,
5. без исключения,



6. сварные швы,
7. достаточно жесткий,
8. безопасность крепления.



## V. Speaking

*1. Attentively read the first and the second paragraphs of the text once again. Try to retell them using these words and word combinations:*

In inspecting the wing; to watch for evidence; injuries to protective coating; is most likely; to occur; water may accumulate; must be kept open; may be broken; as a result of; hard landings; loosened rivets; internal failure; parallel wrinkles; may indicate; frame members.

*2. Make short reports on the following topics:*

1. Inspection of engine mounts.
2. Inspection of cowling fairing.



## **Unit 3**

### **TOPIC: FUSELAGE**

#### **I. Pre-Reading**

*1. Before you read the text answer the following questions.*

1. What kinds of fuselage have most of the present-day airplanes?
2. Is the fuselage of all the airplanes similar in design and location?
3. What about the construction of most present-day airplanes fuselages?
4. What compartments do the large transport planes have?

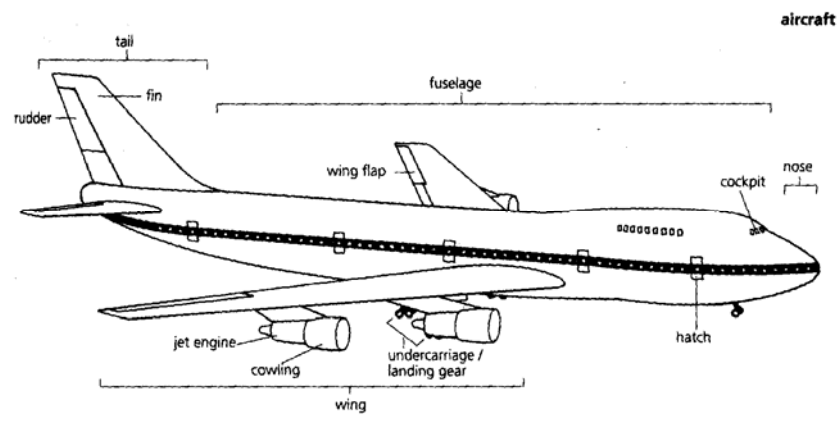

## II. Reading

1. Read the text and check whether your answers were correct.

The fuselage of all airplanes is similar in design and location. The main differences are the size and the use for which the airplane designed. A small, light aircraft has a fuselage to carry one or two passengers, including the pilot, and few pounds of baggage, which make up the entire payload of the airplane. The large transport planes have rows of seats arranged to carry passengers with room in the front of the fuselage for baggage, radio equipment, etc. In this type of airplanes, the pilot and copilot are far forward in the fuselage on a separate compartment from the passengers. The fuselage of cargo-carrying airplanes has large spaces in which cargo may be stored.

In light airplanes, the fuselage may be made of welded steel tubing covered with fabric a wooden framework covered with light plywood, a combination of metal and plywood, or of wood and fabric.

Fuselages of most present-day airplanes are of all-metal construction, often of the monocoque design. The monocoque design relies largely on the strength of skin or shell to carry various loads. The design may be divided into three classes – monocoque, semi-monocoque, and re-enforced

shell. Different portions of the same fuselage may belong to any these classes.

The purely structural effort required to design a large highly pressurized fuselage with numerous cut-outs for windows and doors is formidable one. To make adequate provision against catastrophic failure from fatigue and corrosion on the one hand and from external damage caused by “foreign” objects such as propeller or turbine blades on the other hand, further complicates the task.

The trend today is to make a fuselage of ail-safe design wherein structural safety is provided by the multi-load path concept, ant to achieve this safety for as low a weight penalty as possible.

### **III. Post- Reading**

*1. Read and translate Text “Fuselage”. Fill in the gaps in the sentences using the words with the appropriate meanings:*

1. The fuselage of all airplanes ... in design and location.
2. Fuselages of most present-day airplanes are of ... .
3. The monocoque design ... on the strength of skin.
4. The engine mount is separated from the fuselage by a fireproof ... .
5. The fuselage as a whole must be of a ... shape.
6. Engine mounting must have all the vital parts easily ... .

all-metal construction, relies, is similar, attached, streamlined, accessible, inspection, bulkhead.



2. *Answer the questions on the content of the text:*

1. What is fuselage of a light plane made of?
2. What does the monocoque design rely upon?
3. What classes of the monocoque design do you know?
4. Why is it difficult to design a large highly pressurized fuselage?
5. What is the trend today?
6. What makes up the entire payload of a light aircraft?
7. What are the main differences of all airplanes fuselages?
8. Where may cargo be stored?

## IV. Writing

1. Make up the summary of the text “The fuselage”.



## V. Speaking

1. Retell text “The fuselage” using your summary.



## Unit 4

### TOPIC: COCKPIT AND CABINS

#### I. Pre-Reading

1. *What instruments does the pilot use? Put the right words with the different instruments.*

##### **Airspeed Indicator...**

This instrument shows how fast the aircraft moves through the air; it is similar to a car speedometer.

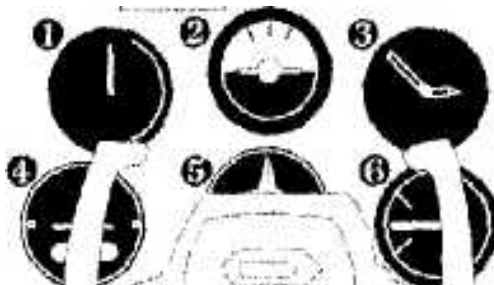

### **Attitude Indicator**

This instrument displays a tiny airplane and a horizon. It shows the position of the plane in the air relative to the horizon.

### **Altimeter**

This instrument shows the aircraft's altitude in feet above sea level.

### **Turn Coordinator**

This instrument features a miniature airplane inside the dial and gauges the plane's rate of turn and direction.

### **Heading Indicator**

This instrument is a directional gyroscope (DG); it acts as a compass to show where the plane is headed.

### **Vertical Speed Indicator**

This instrument measures air pressure during the aircraft's climb and descent.

*2. Before you read the text answer the following questions.*

1. What is important in the inspection and maintenance of the aircraft?
2. What must be kept free from corrosion and cracks?
3. What must be checked before take-off and why?
4. Why should seats be inspected?



## II. Reading

1. Read the text and check whether your answers were correct.

*Visual Check.* Cleanliness, order, and proper installation of equipment are important in the inspection and maintenance of an airplane. Loose objects such as tools, microphones, or flashlights should never be allowed on the floor of cockpit. They may create a serious hazard by jamming the flight controls. Extra length of microphone cords or similar equipment should be coiled and taped to a convenient part of the airplane so that they cannot foul the controls. Regular checks should be made to see that the data and map case in the cockpit contain the required Technical Orders and maps. Before take-off, the cockpit, baggage, and tool compartments must be checked to see that all contents are properly secured so that they cannot damage the airplane during maneuvers. When the ballast is used, a check must be made to see that it is properly located and securely fastened.

*Enclosures, Windshield, and Windows.* The metal frames holding the windshields and windows of enclosures must be kept free from corrosion and cracks. The padding about the individual sections of glass or composition material should be maintained properly in order to minimize cracks resulting from vibration.

*Doors.* Door locks must latch positively and lock or unlock easily. All locks, catches and hinges must be securely attached. The operation of the emergency release must be checked periodically and correction made if it does not work properly. All moving parts are to be oiled lightly at regular intervals.

*Seats and Safety Belts.* Seats should be inspected regularly for cracks or sharp projections which might catch or tear the clothing of the occupant. If a damaged seat cannot be repaired, it should be removed and replaced.

1. When a seat is installed, its attachment and all fittings must be securely fastened. The adjustment must operate easily and positively. The tension of the shock cord must be adjusted to raise the seat easily when the release is operated. Periodic inspection is required to keep all these parts in

good operating condition, inspection includes a careful test on the shock cord as directed in Technical Orders.

2. When a safety belt is installed, it must be checked to see that webbing, straps, seams, etc. are in good condition; that the attachments are secure; that is adjusted correctly; and that the release operates properly. This inspection is repeated at regular intervals.

3. All safety belts must be given a regular weight test. Each type is tested while web and leather parts are adjusted to their greatest length. During the test, a weight of 500 pounds, must be lifted from the floor gently to prevent impact loading – that is, excessive stress due to sudden application of a force – and lowered immediately to prevent unnecessary strain on the material of which the belt is made. No attempts should be made to tear the stitching or webbing of a belt by hand. If any part is found to be defective or deteriorated, or if it shows any evidence of weakening or failure during the test the entire belt will be replaced.

### **III. Post-Reading**

*1. Read and translate Text 6 “Cockpit and Cabins”.*

*Fill in the gaps in the sentences using the words with the appropriate meanings:*

- Before take-off the cockpit, baggage and tool ... must be checked.
- The padding about the individual sections of glass or composition material should be ...properly.
- The operation of the emergency release must be ...periodically.
- The adjustment must ... easily and positively.
- This inspection is repeated at ... intervals.

- All safety belts must be given a regular weight ... .
- Doors locks must launch ... .
- All moving parts are to be ... lightly.

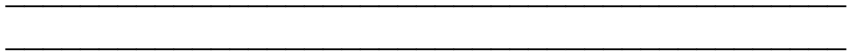

Oiled, test, positively, hacked, maintained, compartments, operate, regular.

2. *Match the words on the left with the appropriate words on the right:*

- |               |                |
|---------------|----------------|
| 1. adjust     | 1. regular     |
| 2. strain     | 2. attachment  |
| 3. loose      | 3. performance |
| 4. operation  | 4. whole       |
| 5. entire     | 5. unfastened  |
| 6. adjustment | 6. fir         |
| 7. periodic   | 7. tension     |

3. *Answer the following questions on the content of the text:*

1. What may create a serious hazard?
2. How must all locks, catches and hinges be attached?

3. Must the operation of the emergency release be checked periodically?
4. What is done with the seat if it cannot be repaired?
5. What must be checked when the safety belts are installed?
6. How is a regular weight test of a safety belt conducted?
7. When is the entire belt replaced?

## IV. Vocabulary Work

*1. Find the Russian equivalents to the following English word combinations:*

- |                                      |  |
|--------------------------------------|--|
| 1. all contents are properly secured | 1. хорошее рабочее состояние                     |
| 2. securely fastened                 | 2. композиционный материал                       |
| 3. to prevent impact loading         | 3. любое доказательство ослабления и повреждения |
| 4. excessive stress                  | 4. прочно зацепленный                            |
| 5. web and leather parts             | 5. быть неисправным или изношенным               |
| 6. to be defective or deteriorated   | 6. избыточное напряжение                         |
| 7. good operating conditions         | 7. тканевые и кожаные части                      |

8. good evidence of  
weakening and failure

8. всё содержимое надёжно  
заперто

9. composition  
materials

9. предотвратить ударную  
нагрузку

*2. Read the text once again and find the sentences with the modal verbs and their equivalents in it. Translate these sentences into Russian.*

*3. Translate the following sentences into Russian:*

1. Proper installation of equipment is important in the inspection and maintenance of an airplane.

2. Flashlights should never be allowed on the floor of the cockpit.

3. They may create a serious hazard by jamming the flight controls.

4. Extra length of microphones cords should be coiled and taped to a convenient part of the airplane.

5. The metal frames holding the windshields and windows must be kept free from corrosion and cracks.

6. The padding about the individual sections of glass or composition material should be maintained properly.

7. All locks, catches and hinges must be securely attached.

8. A damaged seat easily when the release is operated.

9. The tension of the shock-cord must be adjusted to raise the seat easily when the release is operated.

10. A weight of 5000 pounds must be lifted from the floor gently to prevent impact loading.

4. *Translate the following sentences into English using the active vocabulary:*

- Правильная постановка оборудования очень важна при осмотре самолета.
- Незакрепленные предметы, такие как электрические фонари, микрофоны и т.д. могут представлять серьезную угрозу для приборов и экипажа.
- Металлические рамы окон и ветрового стекла должны оберегаться от ржавчины и трещин.
- Трещины в результате вибрации должны быть сведены до минимума.
- Все замки, запоры и петли должны быть надёжно прикреплены.
- Периодически должно проверяться действие рычага аварийного сброса.
- Все движущиеся части должны слегка смазываться.
- Трещины или острые выступы сидений могут зацепить одежду пассажира.
- Если поврежденное сидение нельзя починить, его следует убрать и заменить другим.
- Осмотр привязных ремней проводится регулярно.

**Do the following test trying to give the correct answers:**

1. "Lift" is an upward force that can cause the wing to rise.

- True
- False

2. Name the three rotations in flight:

- ?
- ?
- ?

3. While gliding, if you lose lift suddenly, this problem is called

\_\_\_\_\_.

- Roll
- Stall
- Crash

4. Glider events are not popular any more since the invention of powered flight.

- True
- False

5. Commercial Aircraft can be defined as privately owned airplanes that offer scheduled service to passengers and shippers of cargo.

- True
- False

6. Most commercial airplanes are larger than General Aircraft planes and are designed to carry passengers and cargo from one location to another on a regular schedule.

- True
- False

7. Airspeeds and seating capacity of commercial aircraft saw a great increase during the \_\_\_\_.

- 1920`s
- 1930`s
- 1940`s

8. The world's first large commercial jet airliner was built and flown in the year \_\_\_\_.

- 1952
- 1956
- 1972

9. What does "supersonic" mean?

- Very loud sound
- Faster than the speed of flight
- Faster than the speed of sound



## **Unit 5**

### **TOPIC: FLIGHT CONTROLS**

#### **I. Pre- Reading**

*1. Before you read the text answer the following questions.*

1. What are flight controls?
2. What is the most frequently used flight control?
3. What does the pilot use to change altitude of flight?
4. What are the ailerons?
5. Where is the elevator hinged?

#### **II. Reading**

*1. Read the text and check whether your answers were correct.*

Airplane, or flight, controls are those aerodynamic or mechanical devices which are used by the pilot to control direction, altitude, and speed of an airplane. The mostly frequently used flight control is the rudder, which is a hinged vertical control, used to induce or overcome yawing movements of the airplane about its vertical axis. In this way, the rudder turns the airplane to the left or to the right.

But to do its job efficiently the rudder must be assisted by another flight control, called ailerons. The ailerons are pairs of control surfaces, normally

hinged along the wing span and designed to control the airplane in roll by their differential movement. In so doing the ailerons make the airplanes bank to the left or to the right. So, before executing any turn, the pilot first banks the airplane and only then uses pedals to rotate the rudder in the needed direction.

To change altitude of flight the pilot uses elevator, which is the control for making the airplane climb or dive. The elevator is a hinged horizontal control surface used to make the airplane change its altitude by raising or lowering the tail.

All flight controls are big and heavy aerodynamic surfaces, requiring considerable efforts for their operation. Tabs, or trimmers, are small auxiliary airfoils, attached to the trailing edge of a movable control surface to decrease the rotational effort and also to trim the airplane for varying conditions of power, load and airspeed. Properly trimmed, flight controls feature very low, or near-zero, rotational efforts.

Actuators, actuating systems, or actuating motors are those electric, electro-hydraulic, or hydraulic devices which actually rotate flight controls of an airplane. Actuators get their commands from autopilots, flight controllers, or from on-board computers.

### **III. Post-Reading**

*1. Read the text again and write down all the words that you don't know. Guess the meaning of the words. Compare them with your partner.*

*2. Fill the words into the blanks:*

1. Tabs, or trimmers, are small auxiliary airfoils, attached to the trailing edge of a movable control surface to decrease \_\_\_\_\_, load and airspeed. Properly trimmed, flight controls feature very low, or near-zero, rotational efforts.

2. In this way, the rudder turns the airplane \_\_\_\_\_.

3. In so doing the ailerons \_\_\_\_\_ to the left or to the right.

4. The elevator is a hinged horizontal control surface used \_\_\_\_\_ by raising or lowering the tail.

5. Airplane, or flight, controls are those aerodynamic or mechanical devices which \_\_\_\_\_ of an airplane.

*3. Read the text again and correct the following statements if they are not true.*

- Airplane, or flight, controls are those hydraulic devices which are used by the pilot to control direction, altitude, and speed of an airplane.

- The most frequently used flight controls are the ailerons.

- The ailerons are pairs of control surfaces, normally hinged along the wing span and designed to control the airplane in roll by their differential movement.

- The elevator is a hinged vertical control surface used to make the airplane change its altitude by raising or lowering the tail.

- Properly trimmed, flight controls feature very high rotational efforts.

- Actuators get their commands from engineers.

*4. Answer the following questions on the content of the text.*

- What is flight controls used for?

- Why does the pilot use the rudder so often?

- Can the rudder do its job alone? For what reasons?

- What factors does efficiency of the rudder operation depend on?

- What are the functions of the ailerons in flight?

- What flight parameters can be controlled by the pilot?



## Unit 6

### TOPIC: HELICOPTERS

#### I. Pre-Reading

*1. Study the picture of the helicopter and translate the following definitions using the dictionary:*

**Outside air temperature sensor** measures the temperature of outside air.

**Pilot head** is used for measuring air speed of the helicopter.

**Cabin ventilators** are used for letting fresh air in.

**Battery vents** are used for letting battery gases out.

**Ground power socket** is used for connecting helicopter electrical systems to ground power source.

**Fuel sump drain** is used for draining fuel out of fuel tanks.

**Ground handling wheels** are used for handling the helicopter while on the ground.

**Oleo legs** absorb the shocks at landing.

**Engine access** is used for maintenance of the engine.

1. **Static port** is used for measuring static air pressure. The difference between measured by the Pilot head dynamic air pressure and static air pressure is used for computing true air speed (TAS) of the helicopter.
2. **All-metal bonded blades** of the rotor are used for developing lift.
3. **Tracking tabs** are used for trimming the lift of the individual blades.
4. **Fixed stabilizer with negative incidence** is used for horizontal flight stabilization.
5. **Tail rotor** is used to counteract the torque of the main rotor.
6. **Pitch control mechanism** is used to control the pitch of the tail rotor in horizontal maneuvering.

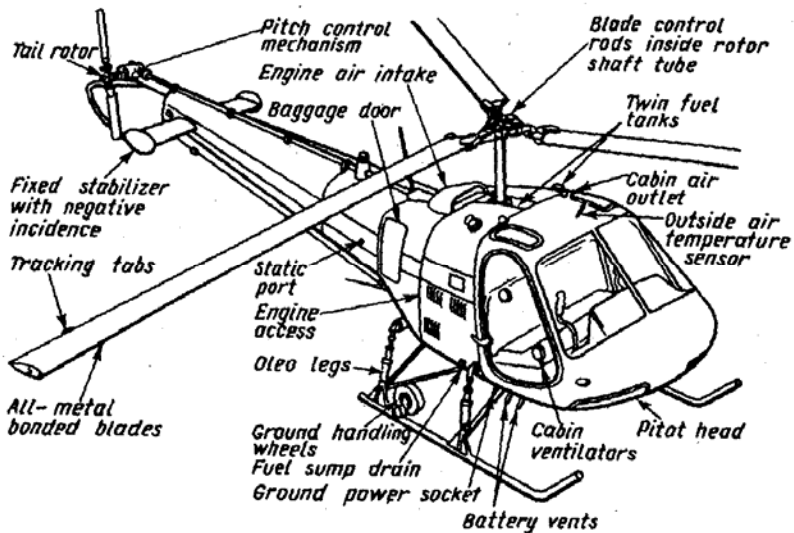

7. **Baggage door** is used for loading and unloading the baggage.
8. **Engine air intake** is used for taking in air for the engine.
9. **Blade control rods** are inside of the rotor shaft tube. They are used to control the lift developed by the main rotor.
10. **Twin fuel tanks** are used for storing fuel.
11. **Cabin air outlet** lets used air out of the cabin.

2. *Before you read the text answer the following questions.*

- 1) Are helicopters rotary-wing aircraft?
- 2) Do conventional airplanes have fixed wings?
- 3) Can helicopters take off and land vertically?
- 4) Is the speed of helicopters high?
- 5) What is the range of copters?
- 6) What level do they normally operate at?
- 7) What crew can a helicopter have?

## **II. Reading.**

*1. Read the text and check whether your answers were correct.*

Helicopters or as they are often called copters are rotary wing aircraft while conventional airplanes are fixed-wing aircraft.

Propulsion system of a helicopter consists of the engine, rotary-wing and drive system, the main horizontal or/and vertical tail propellers which cause the helicopter to fly. Rotating blades send the airflow downward thus creating lift. It enables the aircraft to take off and land vertically. The helicopter needs no runways. It can operate from small unprepared areas. It is also able to load and unload without actually landing due to its hovering capability and special loading equipment. This is one of its greatest advantages as compared to fixed-wing planes.

As for some of its disadvantages we mark its slow speed, inaccuracy due to its vibration as well as noise generated by the rotors.

At present helicopters are extensively used for peaceful and military purposes and as a result of that there is a great variety of helicopter types and designs.



Helicopters are capable of high performances. Speeds for rotary craft range from zero (in hovering flight) to more than 300 kmph. They can reach 5,500 m (10,000 feet) above the ground but normally they operate at ground level. Payload of large helicopters amounts to 50 tons.

The crew necessary for operation consists of the pilot alone or two-three or more members: pilot and copilot who does the navigation's duties, board engineer and an operator. So in all the cases the advantage of the helicopter namely its independence from airfields allows it to reach and do the work in area; inaccessible for fixed-wing aircraft.

### III. Post-Reading

1. *Read the text again and write down all the words that you don't know. Guess the meaning of the words. Compare them with your partner.*

2. *Fill the words into the blanks:*

1. The crew necessary for operation consists of the pilot alone or two-three or more members: \_\_\_\_\_ board engineer and an operator.

2. Rotating blades \_\_\_\_\_ thus creating lift.

3. As for some of \_\_\_\_\_ inaccuracy due to its vibration as well as noise generated by the rotors.

4. At present helicopters are extensively used for \_\_\_\_\_ and as a result of that there is a great variety of helicopter types and designs.

5. Helicopters or as they are often called copters are rotary wing aircraft \_\_\_\_\_.

3. *Find in the text pros and cons of using a helicopter.*

4. *Read the text again and correct the following statements if they are not true.*

1) Rotating blades send the air stream upward, thus creating lift.

2) Helicopters can operate only from concrete runways.

3) Copters are able to load and unload without actually landing.



4) Rotary-wing aircraft are characterized by supersonic speeds.

5) Helicopters' propulsion system differs from that of the conventional aircraft.

6) Only a crew of six can operate a helicopter.

5. Read the additional text on the history of helicopters and answer some questions on the content of the text.

- When was the first semi-practical idea of a human carrying helicopter conceived?
- Who was the word "helicopter" (*helicoptere*) coined by?
- What did the availability of lightweight turbo shaft engines in the second half of the 20th century lead to?
- When did mass production of the military version of the Sikorsky XR-4 begin?
- Who was a flight of the first fully controllable helicopter demonstrated by?
- When were reliable helicopters capable of stable hover flight developed?

Since 400 BC the Chinese had a bamboo flying top that was used as a children's toy. This toy eventually made its way to Europe and has been depicted in a 1463 European painting.

*Pao Phu Tau* was a 4th century book in China that described some of the ideas in a rotary wing aircraft. The first semi-practical idea of a human carrying helicopter was first conceived by Leonardo da Vinci around 1490.

The word "helicopter" (*helicoptere*) was coined in 1861 by Gustave de Ponton d'Amecourt, a French inventor who demonstrated a small steam-powered model.

But it was not until after the invention of the powered airplane in the 20th century that actual helicopters were produced. Developers such as Jan Bahyl, Oszkar Asboth, Louis Breguet, Paul Cornu, Traian Vuia, Emile Berliner, Ognoslav Kostovic Stepanovic and Igor Sikorsky pioneered this type of aircraft, with Juan de la Cierva introducing the first practical autogiro in 1923 that was to be the basis for the modern helicopter.

A flight of the first fully controllable helicopter was demonstrated by Raul Pateras de Pescara 1916 in Buenos Aires, Argentina. In 1922, Albert Gillis von Baumhauer, a Dutch aeronautical engineer, started studying the possibilities of VTOL rotor craft. His first prototype 'flew' ('hopped' and hovered really) on September 24, 1925, with Dutch Army-Air arm Captain Floris Albert van Heijst at the cyclic and collective (both are Von Baumhauer inventions). Patents were granted Von Baumhauer by the British ministry of aviation January 31st, 1927, under number 265,272.



In 1931, Soviet aeronautical engineers Boris Yuriev and Alexei Cheremukhin began experiments with the TsAGI 1-EA helicopter, also a single lifting rotor helicopter, with forward and aft anti-torque rotors. It reached an altitude of 605 meters (1,984 ft) on August 14, 1932 with Cheremukhin at the controls. The German Focke-Wulf FW-61 was the first production fully controllable helicopter and had its first flight in 1936. The FW-61 broke all world records in 1937. Nazi Germany used the helicopter in

combat during World War II in small numbers. Models such the Flettner FL 282 Kolibri were used in the Mediterranean Sea.

Mass production of the military version of the Sikorsky XR-4 began in May 1942 for the United States Army and was used over Burma for rescue duties." It was also used by the Royal Air Force, the first British military unit to be equipped with helicopters being the Helicopter Training School, formed in January 1945 at RAF Andover with nine Sikorsky R-4B Hoverfly I helicopters.

The Bell 47 designed by Arthur Young became the first helicopter to be licensed (in March 1946) for certified civilian use in the United States. Two decades later the Bell 206 became the most successful commercial helicopter ever built with more hours and has set more industry records than any other aircraft in the world.

Reliable helicopters capable of stable hover flight were developed decades after fixed wing aircraft. This is largely due to higher engine power density requirements when compared with fixed wing aircraft. Igor Sikorsky is reported to have delayed his own helicopter research until suitable engines were commercially available. Improvements in fuels and engines during the first half of the 20th century were a critical factor in helicopter development. The availability of lightweight turboshaft engines in the second half of the 20th century led to the development of larger, faster, and higher performance helicopters. Turboshaft engines are the preferred powerplant for all but the smallest and least expensive helicopters today.



6. Read this text again and decide if these statements are true or false. Correct the false ones.

1. Since 400 BC the Chinese had a bamboo flying top that was used as a children's toy.

2. In 1982, Albert Gillis von Baumhauer, a Dutch aeronautical engineer, started studying the possibilities of VTOL rotor craft.

3. SSAU used the helicopter in combat during World War II in small numbers.

4. The Bell 47 designed by Arthur Young became the first helicopter to be licensed (in March 1946) for certified military use in the United States.

5. Developers such as Jan Bahyl, Oszkar Asboth, Louis Breguet, Paul Cornu, Traian Vuia, Emile Berliner, Ognoslav Kostovic Stepanovic and Igor Sikorsky pioneered this type of aircraft, with Juan de la Cierva introducing the first practical autogiro in 1923 that was to be the basis for the modern airplane.

6. Igor Sikorsky is reported to have delayed his own helicopter research until suitable engines were commercially available.

